



Miles 'n' Smiles

Studebaker Drivers Club San Joaquin Valley Chapter

www.sdcsanjoaquinvalleychapter.com

July 2023

No Regular Meeting in July

SJVC 30th Year Celebration BBQ Potluck

July 15 @ 4 p.m. For more information, see Page 9

WHAT'S INSIDE

President's Message
Cover

SEMA Action
Page 2

Meeting Minutes
Pages 4-6

Calendar of Events
Page 7

Club Calendar Project
Page 8

30th Anniversary, BBQs
& Photos
Pages 9-10

Revisiting the Weasel
Page 11

Studebaker Trading Cards
Page 12

Buying White Sidewalls
Page 12

Studebaker on Film
Page 13

Name that Car!
Page 14

Notes from the
Studebaker Nation
Page 16

The Way We Were
Page 18

Tech Tips
Page 19

Classified Ads
Page 20



1960 Lark wagon

President's Message – Anne Goodman

Hello Studebaker Family,

Boy, time sure flies. Before you know it, our club turns 30.

At our annual BBQ at the Gustafsons on July 15, we all should be bringing mementos and pictures from the last 30 years to share. It is going to be a fun time.

I went back to work at the Grizzlies Stadium downtown. It has been interesting. I wasn't sure if I could keep up, but I have managed to. It's a different mindset for me. I am still competitive but on a different level.

Car show season is in full bloom now. I got Mabel out the other day and washed her and drove her around the neighborhood. I'm going to take her to a car show soon, maybe the Friday night at the Church on Fowler North of Nees.

Shortly after the Club B,BQ in July David and I, along with my brother Johnny, will be headed to Charleston, Missouri to take a tractor to Marc. We will stop along the way to see friends and relatives in Troy, Missouri, right by St. Louis. We will have an empty trailer on the way

(See Message, Page 2)

Finally I understand why cars have these things



SAN Urges Action Against New EPA Emissions Rule

According to SEMA Action Network, the U.S. Environmental Protection Agency's (EPA) proposed federal emissions standards for new motor vehicles in model-years 2027-2032 is deserving of opposition.

SAN states that the standards are "intended to dramatically increase sales of electric vehicles (EVs) and will stifle fuel technology innovation."

SAN is urging concerned citizens to contact the EPA and express that "you oppose their efforts to use the vehicle emissions standards to phase out sales of [internal combustion engine] vehicles."

The EPA estimates that 67% of new passenger vehicles sold in the U.S. would be EVs by 2032 under its proposed standards.

"SEMA has serious concerns with this proposal, which aggressively seeks to lower carbon emissions under timelines that effectively make electric vehicles the only option for automakers to meet its requirements," according to the online story.

To read the entire statement, and for more news and information from SAN follow this [link](#).

Message

(Continued from Cover)

back. Hmm.

Over 2,000 miles one way. I figure gas alone should be \$2,000. Well, you only live once. Probably our last long-distance trip, well at least until the price of gas becomes reasonable again.

Your Officers

President

Anne Goodman
1296 N Poplar Avenue
Fresno, CA 93728
559-475-3525

Vice President

Webmaster
Robert W. Nunes
4105 N. Hammel Way
Fresno, CA 93727
559.230.9132

Treasurer

Debbie Raimondi
8097 N. Sunnyside Avenue
Clovis, CA 93612
559.313.9107

Secretary/Membership

Susan Thomason
43306 Running Deer Drive
Coarsegold, CA 93614
559.641.5125

SDC Zone Director

Ed Smith
P.O. Box 90763
White Mountain Lake, AZ
85912
602.290.1045

SDC Zone Coordinator

Dan Scott
2571 Palermo Court
Murrieta, CA 92563
818.558.1791

SDC Regional Manager

Louis Van Anne
5802 Land View Drive
Stockton, CA 95219-4602
209-479-0867

Newsletter Editor

Robin Shepard
2248 Fourth Street
Atwater, CA 95301
209.628.1537

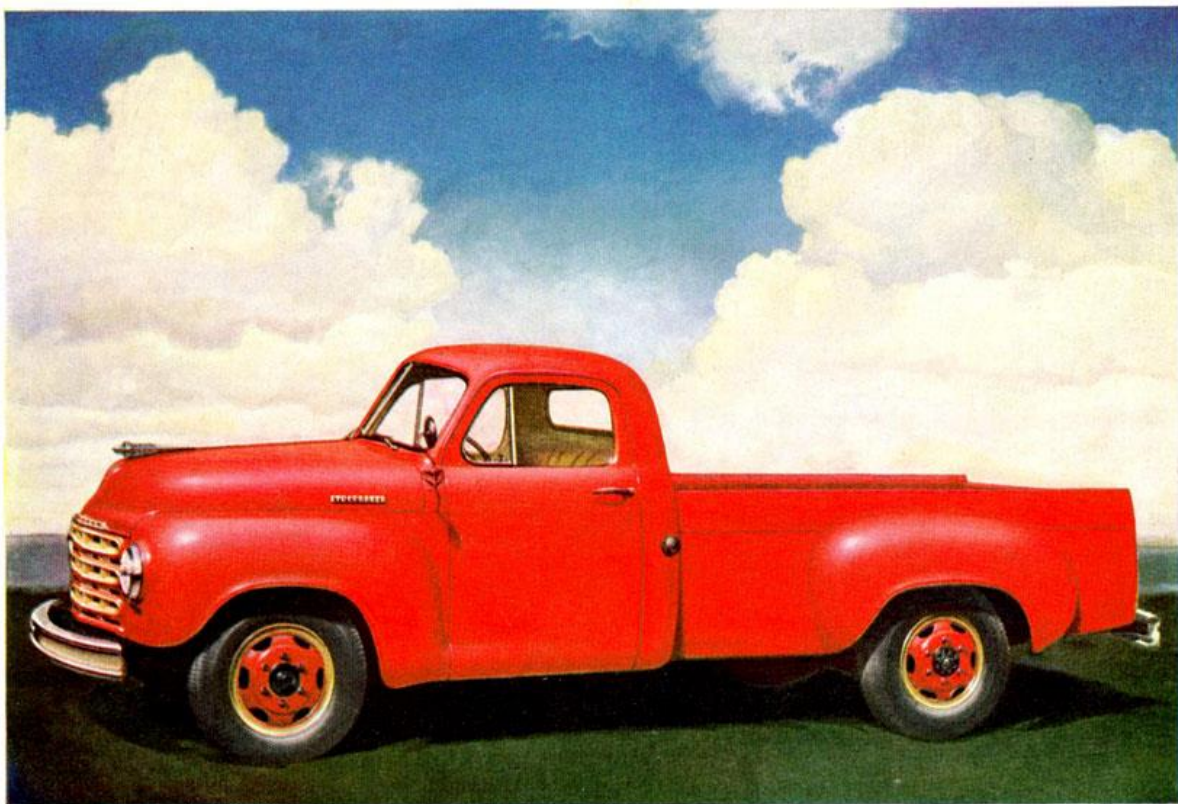

THREE-QUARTER-TON 8 FT. PICK-UP

Announcing new
**1949 STUDEBAKER
 TRUCKS**

America's newest and finest!

AMERICA'S first 1949 motor trucks are here! They're handsome, rugged, superbly powered, brilliantly engineered new Studebakers!

Yes, Studebaker, first by far with a postwar car, now paces transportation progress still more . . . revolutionizes motor truck design and performance!

These new 1949 Studebaker trucks are outstanding in postwar features that you haven't seen before!

They're America's first trucks with an exclusive new kind of "lift-the-hood" accessibility!

Their cabs have astonishing new spaciousness — undreamed of new comfort — amazing new visibility!

This Studebaker super line for '49 is in full production right now, in a huge modern plant with every advanced facility for truck manufacture! More models than Studebaker ever offered before! An impressive variety of sizes and wheelbases!

Go to a Studebaker showroom for a close-up look at these sensational new 1949 trucks — they're the nation's postwar pace-setters in low-cost hauling!



HALF-TON 6½ FT. PICK-UP



ONE-TON 9 FT. STAKE



1½-TON SHOWN WITH 12 FT. CLOSED VAN



2-TON SHOWN WITH 2½-3 CU. YARD DUMP

San Joaquin Valley Chapter Studebaker Driver's Club
Fresno, California

MEETING MINUTES – June 13, 2023

CALL TO ORDER

President Anne F. Goodman called the meeting to order at 6:50 p.m. at Black Bear Diner, 3602 W Shaw Ave (at N Marty Ave), Fresno, CA 93710.

ATTENDANCE

David, Anne F., Ashley, Rebecca & Cassie Goodman **	Buzz & Sue Madsen
Debbie Raimondi	Dave & Elaine Goudelock
Robert Nunes	Frank Wenzel
Rob Nunes	Kent Vandenberg
Bruce Novak	Mike McKinney & Debra Foltz
Greg & Edith Gustafson **	Kurt Zellman
Herb & Pat Helzer	Carl & Susan Thomason
Jim & Karen McKeever	
John & Robin Johnson **	** Drove a Studebaker/Classic Car

RECOGNITION of NEW MEMBERS & GUESTS

We recognized new chapter members, **Don & Jean Stephens**, who have a 1959 Lark. We also welcomed Mike Bird and John Hartney, relatives of Jim McKeever's, visiting from Des Moines.

MINUTES

It was moved by member **Frank Wenzel** and seconded by member **Robin Johnson** to approve the minutes of the May meeting as corrected. Approved.

TREASURER'S REPORT

It was moved by member **Frank Wenzel** and seconded by member **Buzz Madsen** to approve the Treasurer's Report for May as follows. Approved.

May 2023

Beginning Balance	\$4,884.17
Receipts \$77 – 50/50 May Mtg	\$77.00
Disbursements None	\$0
Ending Balance	\$4,961.17

PRESIDENT'S REPORT

President Anne shared that she is working at the Grizzlies Ball Park now and has the sore feet to show she is getting her daily allotment of steps & exercise. She said it may cause her to miss some club events.

She also reminded members about the Friday night car shows at the Clovis Missionary Baptist Church on Fowler & Nees. Quite a few of our members attend. Great cars, friendly people, lots of shade and they serve hamburgers, hot dogs & ice cream. No cost but donations go to the church's Rapha Ranch ministry.

TOUR MASTER'S REPORT

Carl Thomason asked **Mike McKinney** and **Debra Foltz** to talk about the BBQ Potluck they are hosting on Saturday, June 17 from noon to 3 p.m. A sign-up sheet was passed around. We'll send out an email with the address and details. **Rob Nunes** isn't able to attend but asked if someone could take pictures for the club FaceBook page and the newsletter.

Also, instead of a regular meeting in July, we have our annual BBQ Potluck hosted by **Greg & Edith Gustafson** on Saturday, July 15. Details will be sent. Please bring pictures of past club events & any Studebaker memorabilia to share to celebrate our chapter's 30th year. The Gustafsons said if you drive your Studebaker, you'll be eligible for a special prize. A sign-up sheet was passed around.

Frank Wenzel invited members to attend the Antique Studebaker Club Meet in Mariposa that he and Kent Vandenberg are hosting 8/3 – 8/6. We'll send details.

The Bowling alley at Fresno State is open on Saturdays now. Debbie will make the reservation for 8/19 at 4 p.m. After bowling, we'll go to Mountain Mike's Pizza on Herndon & First St. A sign-up sheet was passed around. Cost will be determined based on how many are attending.

We also need to decide on an activity for September 9th – International Drive Your Studebaker Day.

MEMBER DISCUSSION

Frank Wenzel said they just finished the 1924 and are working on the 1935. He also shared that Francis Asbury, who lives in Mariposa in the Bootjack area, has 10 Studebakers he is ready to let go. Frank bought a Studebaker fire truck from him years ago and will get more information.

At the La Palma Studebaker Show, Frank said they learned that designer and car enthusiast Jim Powers had passed away. He developed the design concept for the 1961 Thunderbird and many of his designs and concepts are in the Smithsonian. There was also a connection to the 1966 Studebaker but I didn't get the details.

Greg Gustafson stressed the importance of the Safety Tip at the end of the article in the newsletter about radiator maintenance. Don't take the pressure cap off a hot engine!

Members were reminded that **Robin Johnson** is our chapter Sunshine Coordinator. Please contact her if you are aware of anyone in the club who is ill, having a medical condition or has lost a loved one. (559) 999-4264. She will call and/or send a card from the club.

OLD BUSINESS

Edith Gustafson presented the pricing for business cards with the chapter meeting and contact information. There were two designs for members to choose from. Edith will order 500 and have them at the BBQ on 7/15. These will be for members to hand out when they meet someone interested or at a car show.

Carl ordered copies of *The Studebaker Story* for members to give out also. No cost to the chapter.

We have new members and some members have misplaced the name badges we ordered three years ago so it's time to place another order. Susan will get the current pricing.

NEW BUSINESS

There was no new business.

50/50 OPPORTUNITY DRAWING

\$51 was won by Lucky member **Greg Gustafson** with \$51 going into the Club treasury.

ADJOURNMENT

The meeting was adjourned at 7:35 p.m.

Submitted by **Susan Thomason**, Secretary/Membership



Studebaker Builds World's Largest Auto — 41 Feet Long



Mammoth auto is located outside the Studebaker proving grounds. Compare it with the roadster.

AT THE entrance of the Studebaker proving grounds, in South Bend, Indiana, stands the world's largest automobile—so large that an ordinary car can be placed under its hood. This mammoth car, shown above, weighs five and a half tons, and is 41 feet long—two and a half times the length of the ordinary car.

SAN JOAQUIN VALLEY CHAPTER – STUDEBAKER DRIVERS CLUB

2023 ACTIVITIES

*Chapter Meetings are on the 2nd Tuesday of each month except July & December
Details & other events will be added as we receive additional information.*

MONTH	ACTIVITIES
JULY	7/15 – Chapter 30 th Year Celebration BBQ Potluck Hosted by the Gustafsons
AUGUST	8/3-8/6 – Antique Studebaker Club/SoCal Chapter Mariposa Meet Hosted by Frank Wenzel & Kent Vandenberg. Details to be sent. 8/18 – Race cars on display at Old Town Clovis Farmers Market 8/19 – Bowling at Fresno State 4 pm. Cost/person TBD. Mountain Mike’s Pizza afterward.
SEPTEMBER	Sat 9/9 – TBD – International Drive Your Studebaker Day
OCTOBER	10/21 – 3 rd Annual Car Show, Willow Creek Healthcare Center, Clovis. No registration fee. Contact Shayna Nagle. 559.977.6812
NOVEMBER	11/11 - Veterans’ Day Parade
DECEMBER	12/9 – Chapter Holiday Luncheon/Old Spaghetti Factory (No Regular Meeting in December)

Ongoing events

Cars & Coffee, Saturdays, 8-10 am, NW corner of Fowler and Ashlan, Clovis

Clovis Missionary Baptist Church Car Shows, Friday nights, Fowler & Nees – May through September 6-9 p.m.

Member suggestions

Cruise night at the A & W in Exeter. Or, a driving tour to the Exeter area with a visit to a great pizza place in Lindsey. Any others?

Future SDC International Meets

Sept 12-16, 2023, Manitowoc, WI
June 25-29, 2024, Dubuque, IA



Rodger Scott and his boss awesome R series truck can be seen at Cars & Coffee on Saturdays.



SJVC Car Club Calendar Project

Wouldn't Lou and Debbie Raimondi's beautiful 1960 Hawk look good in a calendar, all on a page of its own? That's the idea of our club project of creating a calendar of our beloved automobiles.

If there's sufficient club interest, we can likely get a calendar produced for 2024. The estimated cost of each calendar is in the neighborhood of \$20.

Send a couple of good photos of your favorite Studebaker with a brief description to r-m-s_57@comcast.net

We're Celebrating our Chapter's 30th Year!

SJVC Members Host Annual Potluck BBQ & Picnic
Come share good food, fun & fellowship
With your Studebaker friends at this annual SJVC EVENT!

Saturday, July 15 at 4 p.m.

Hosted by Greg & Edith Gustafson
10151 Rolling Hills Drive, Madera 93636
Call 559.269.5244

Super Chef Lou is still in charge of preparing the meat, provided by the club.
Bring a side dish, salad or dessert to share (not just chips & dip, please!)
and your own beverage (drinks not provided)

Bring your own chairs too!

Plates & utensils will be provided.

If you'd like to swim, bring your suit & a towel.

Drive your Studebaker – be eligible for a special prize!
Also bring any club photos or history & Studebaker memorabilia to share.
We'll have display tables set up.

Please RSVP by Monday July 10 so we know how much meat to buy!
Call Carl or Susan Thomason at (559) 641-5125 or email at thomason2@earthlink.net

A Big Thank You!

We appreciate Mike McKinney-Black & Debra Foltz for hosting the club again this year for a mid-day BBQ Potluck on June 17. Mike is a superb BBQ chef and made delicious burgers and hot dogs.

The best thing about potlucks is the terrific variety of different foods to sample. We all took advantage of the selection! There was plenty of shade and we had a great time visiting under the citrus trees.

It was fun to have the Studebakers parked in Mike's large front yard. **(To see some photos, go to the next page.)**

Here's the group who attended: Lou & Debbie Raimondi (1964 GT Hawk), Greg & Edith Gustafson (1950 Champion), Buzz & Sue Madsen (1949 Pick-up "Crusty"), Herb & Pat Helzer (1951 Kaiser), John & Robin Johnson (1959 Ford Wagon), Marc & Shiela Varney, Jim & Karen McKeever, Carl & Susan Thomason.

Submitted by Susan Thomason

SJVC BBQ — June 17, 2023

A Classic Day!

Friends, Food & Studes!



Photos By

Buzz Madsen



Revisiting the M29 Weasel

In 1941, the Allies, planning raids on German heavy water facilities in Norway, needed a fast, maneuverable all-purpose vehicle that could scamper quickly over snow. Soon the Studebaker Company in Indiana was producing the M29 Weasel, but not before the Norway plan was scrapped.

Luckily, the tracked Weasel could navigate not only snow, but also swamps, mud, and sand, catching the eye of U.S. military brass, who quickly pressed the M29 into action as a frontline cargo carrier, ambulance, mobile command center, and cable layer for Signal Corps units. Along with its drivability on winter battlefields, the Weasel's semi-amphibious abilities served it well crossing Europe's rivers and marshes, as well as in the landings at Sicily and Normandy. Though the spry vehicle, designed for arctic conditions, often overheated in more temperate battle zones. All the same, the M29's adeptness at negotiating sandy beaches made it a critical U.S. asset in the Pacific invasions of Iwo Jima and Okinawa. After the war, most M29s were sold off as surplus, often to winter sports resorts.



Thanks to the Vancouver Island Chapter, The SD Hawk, Dakotas Chapter. Source: VISTA, Vancouver Island Chapter

Studebaker Trading Cards. Collect Them All!

Died: July 14, 1986, (Monday) [Age 92]

Born: November 5, 1893 (Sunday)

Birthplace: Paris, France

Height: 5' 10"

Children: *Laurence Loewy* (1953–2008) [Age 55]

Spouse: *Viola Erickson Loewy* (m. 1948–1986),
Jean Thompson Loewy (m. 1931–1945)

Education: University of Paris (1910)



Time magazine
October 31, 1949

Raymond Loewy

French-American industrial designer

Raymond Fernand Loewy was a French-born American industrial designer who achieved fame for the magnitude of his design efforts across a variety of industries. He was recognized for this by Time magazine and featured on its cover on October 31, 1949.

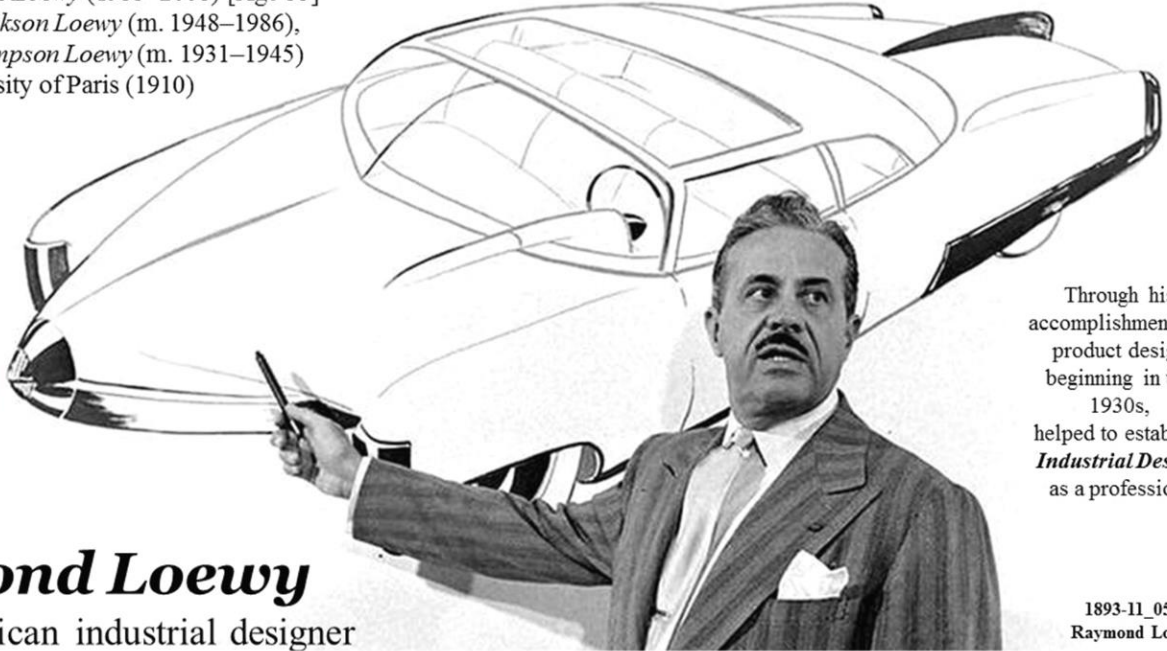

Through his accomplishments in product design beginning in the 1930s, helped to establish *Industrial Design* as a profession.

1893-11_05 --
Raymond Loewy

White Sidewall Tires Can Still be Found

*By Jerry Blount
Northwest Chapter, Oregon*

Tires for our Studebakers . . .

Many of us, particularly with daily driver Larks, like the look of a whitewall tire on our cars. The narrow "inch wall" tires have been available for decades - but like everything else, that is now changing.

Without going into a debate about tire sizes, I will say that a P205/75R15 is a fairly universal replacement tire for our Studebakers. This replaces the "old" 6.70 X 15 size that would have been on our cars when they left the factory.

"P" (may or may not be present) means passenger car, 205 is the tire cross section width in millimeters (approx. 8.07 inches), 75 is the aspect ratio (%) of the section height to width - in this case about 6.05 inches. "R" means radial construction, and of course 15 is the wheel diameter in inches.

For years, tire manufacturers made this size with a narrow whitewall. But as time went by, with new cars having much different diameters and aspect ratios, not to mention white side walls no longer being used on current production cars - the market was disappearing.

Most recently, Cooper Tires had their "Trendsetter" line on tires that had our desired size and whitewalls available, but now these have been discontinued. (As of June 2021, Cooper became a subsidiary of Goodyear.)

Larry Coleman of Industrial Tire Service did find a couple of current sources for suitable whitewalls, which are 1) Uniroyal Tiger Paw AWP II; and, 2) Nexen AH5.

Larry Coleman can be reached at: Industrial Tire Service, 7331 NE Killingsworth, Portland, OR 97218, or you can call him at 503-256-1016.

Studebaker on Film



Veteran Carrera Panamericana Racer in Europe

Here's a satisfying video in under two minutes. This 1953 Commander race car, an oft-seen contender in the revived Carrera Panamericana race in Mexico, is seen here hitting the circuit in Europe.

According to Wikipedia, "The bulk of [Carrera Panamericana] entries are provided by 1950s and '60s American stock cars; the most popular shapes are the 1953/54 Studebaker Starliner hardtops and Starlight pillared coupes, originally designed by a team led by famed industrial designer Raymond Loewy, because of their exceptional aerodynamics.

"This is best proven by the fact that as of 2016, out of 29 modern-era races, 22 have been won by Studebakers. "

Click on the photo link above to see the video. If you have suggestions for other videos to post, contact me at r-m-s_57@comcast.net



Name That Automobile!

Here's a fun exercise. Using this street scene from late '50s Philadelphia, write down the year, make and model of each car you can identify.

How many did you come up with? Share your list with your fellow club members. There's no prize for the person with the most correct answers, but you'll have earned our admiration, so give it a try anyway.

\$10 PER CAR,
PER EVENT



RODS *on the* BLUFF 2023



PARK PLACE AT PALM & NEES

FIRST FRIDAY OF THE MONTH

APRIL 7TH • MAY 5TH • SEPTEMBER 1ST • OCTOBER 6TH

- OUR PROUD SPONSORS -

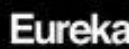
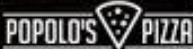

FOR MORE INFO VISIT:

WWW.HOTRODCOALITION.COM

PHONE: 559.825.6608

EMAIL: INFO@HOTRODCOALITION.COM



Notes from the Studebaker Nation – Robin Shepard

The evolution of the automobile is as much about advancing technology as it is about changing consumer tastes.

Many former features of automotive style and accessories have disappeared over the decades, some due to technology, others to evolving consumer attitudes.

The once ubiquitous ashtray and 12-volt lighter have been replaced by climate controls and electronic charging stations. But first, the consumer decided to give up smoking.

Same with CD and cassette decks. No one listens to them anymore, so bye bye Miss American Pie.

The luxury of full bench seats, which allowed three people up front, has given way to sculpted bucket seats with electronic heating and adjustments in every direction.

They may provide optimal seating positions, but the wide and deep bench seat gave the driver a lot of room to shift his weight into a more comfortable position. Besides, he could haul his date closer to where he was sitting.

Now, that's comfort.

Improvements in technology, I get. But what if I want a full-size spare tire? Good luck finding one in a new car.



And how about giving us a modern car with hideaway headlights? That's a cool design feature that's all but disappeared, but one for which modern technology could actually improve.

I guess we don't need manual telescopic antennas and window cranks. They've changed for the better.

Exterior door keyholes are becoming outdated also, but if you've ever locked your keys in your old car, there's a locksmith who can still pick it open.

It's easy to wax nostalgic about the old days and our old automobiles. Remember the rear-facing seat in the back of your parents' station wagon? Another cool idea lost to time.

When I think about all of the odd and eccentric gizmos cars used to have, from the spinning traveler's compass mounted on the dash to the traffic light viewer, I guess my favorite would have to be the curb feeler.

It vanished long before proximity sensors were developed, but in its day many a wheel was saved from a nasty rash. Besides, curb feelers just looked cool, and they'd perform just as well today.

It was my buddy Marty who immortalized the curb feeler in high school.

Marty was a real joker. He had a quick putdown for anyone at any time. He'd mock an

Irish brogue and announce, "Aye lad, why don't you go suck a curb feeler."

Now that's still funny. At least it is to someone of my twisted generation. It's going to be lost on a millennial who's never seen one of these dinosaurs of the automobile accessory realm.

A good joke depends on it being relevant to the times. My friend's curb feeler joke wouldn't find an audience today.

Maybe, "go kiss a catalytic converter," would get today's twenty-something laughing. Who knows?

There might be a joke in cool air intakes and adjustable coil over shocks, but I don't think Marty would find much humor in modern cars. They don't have enough oddities to drool over.

Come to think of it, hideaway headlights are a likely source of risqué humor, headlights being a euphemism for a woman's bosom.

But I digress.

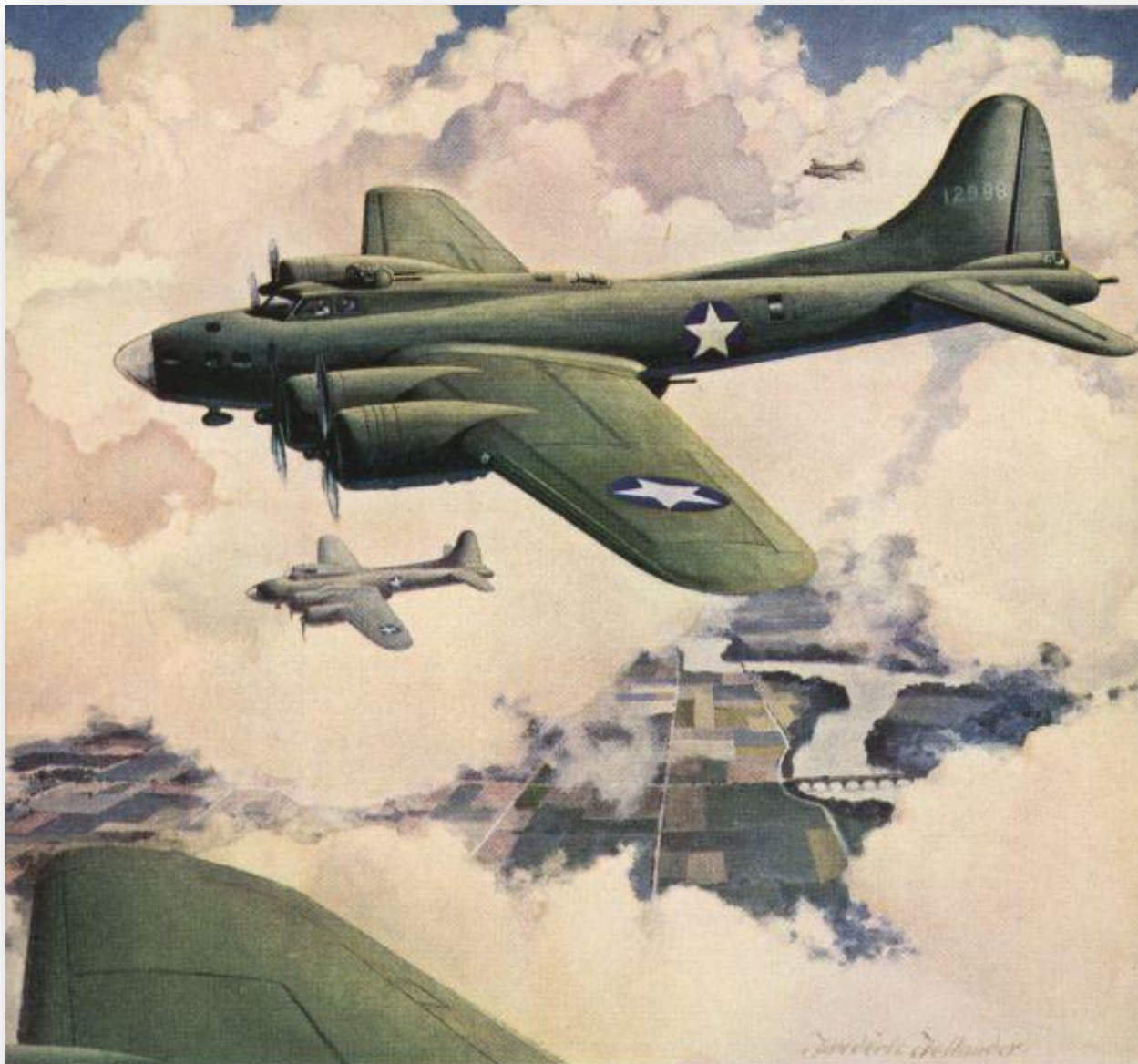

Studebaker craftsmen again give "more than they promise"

The devastating bombing power and matchless fighting power of the Boeing Flying Fortress make comforting daily items in the war news.

Studebaker, America's oldest manufacturer of highway transportation, is privileged to collaborate with Wright, America's oldest producer of airplane engines, in providing flying power for this invincible dreadnaught of the skies. And Studebaker is also building much other war matériel, including tens of thousands of big, multiple-drive military trucks for the forces of the United Nations.

Today, as for generations past, Studebaker craftsmen make their watchword—"give more than you promise." Every Studebaker employee is justly proud of the achievements of his organization in the arming of our Nation and its Allies.

BUY
U. S. WAR
BONDS



War Trucks for the United Nations! Studebaker, famed for years for dependable transportation, has now become one of the largest producers of big, multiple-drive military trucks for the forces of the United Nations.

Studebaker BUILDS WRIGHT
CYCLONE ENGINES
FOR THE *Flying Fortress*

The Way We Were

Studebaker First with New Postwar Look



Studebaker is “First by Far with a Postwar Car.” The company’s new 1947 Champions and Commanders debut in May and feature radical styling by Raymond Loewy Associates.

Courtesy of Studebaker National Museum

“The ultimate concept car will move so fast, even at rest, as to be invisible.”
— J.G. Ballard, author of ‘Crash’

Tech Tips

You Can Still Teach an Old Car New Tricks

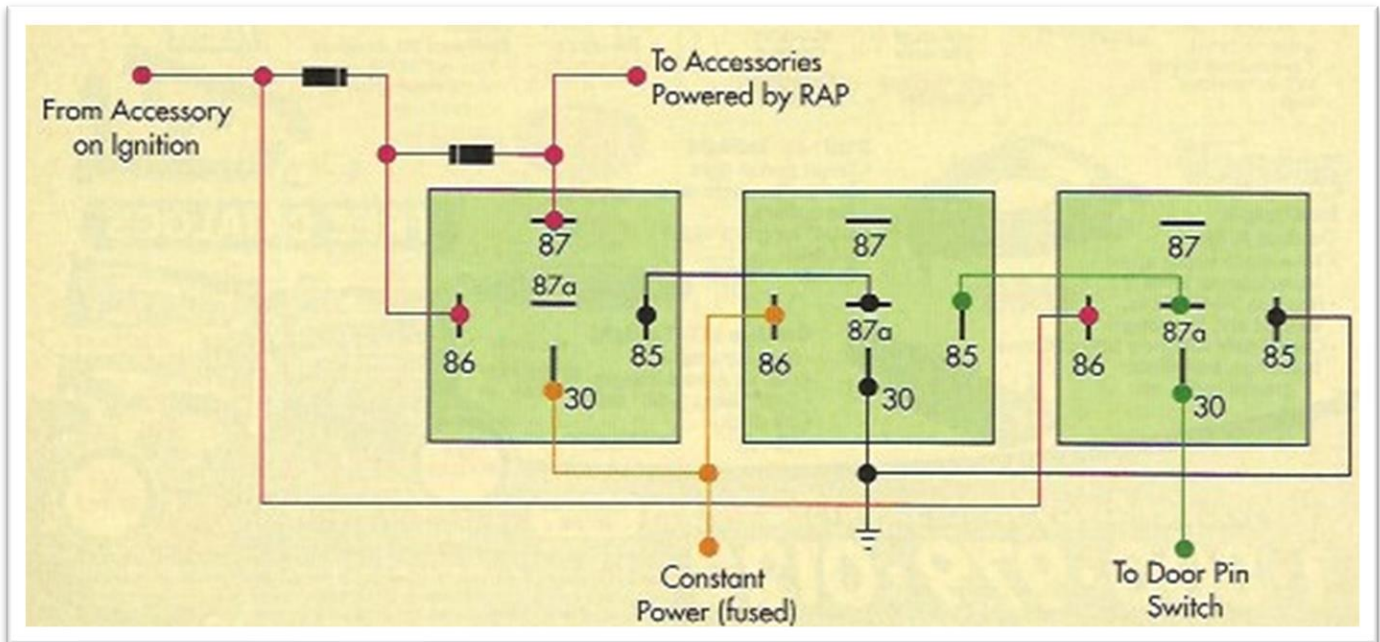

**By Jim McKeever
& Karen McKeever
San Joaquin Valley Chapter/SDC**

I was sitting in our “Cadi-baker” the other day, waiting for my wife to return something to the store (“I’ll only be a minute,” she said).

At that point I noted how convenient it was that the radio stayed on, and the power windows still operated, even with the key out of the ignition, until I opened my door.

This type of circuit is called Retained Accessory Power or RAP. On newer cars the Body Control Module controls the RAP and keeps it activated for up to ten to twenty minutes, depending on the year, make, and model, of the vehicle.

However, you can add RAP to your older vehicle quite easily and it is a low-cost installation.

You will need three relays (note these are 12-volt relays in case you are still a 6-volt person), two 1N5402 diodes (or 3 amp equivalent) and two door switches that are probably already in your vehicle (if you have a dome light that comes on when you open the door, you already have them.)

After disconnecting the negative battery terminal, follow the diagram above, paying attention to the bands on the diodes, as they indicate which direction they need to be installed. Remember, star washers are your friend anytime you run a wire to ground.

Re-connect your battery and test out our work. Turning on your vehicle or going to accessory will now activate the RAP feature. When you turn off your car the RAP feature will stay activated until the door is opened. You now have a new car feature in your old car.

(Information in these Tech Tips is based on the writer’s own research, experiences, and viewpoints. The information, and links to other websites, is to be viewed and/or used at your own risk. The writer makes no guarantees regarding the outcome of the use of the material, products, or resources in this article and is not responsible for any loss or damage incurred. Adjustments or modifications may be needed for your specific vehicle. Remember to use all standard safety equipment and precautions.)

Studebaker

Classified Ads

Sitting on extra Studebaker parts? Looking for parts? This is the space for club members to advertise their needs. If you have something to sell or something to buy, send your information to r-m-s_57@comcast.net.

Various '49 Coupe Parts Available

I've got various chassis and engine parts from a '49 Champion. These include the steering column, generator, engine in need of rebuilding, rear leaf springs, etc. If you're looking for something, let me know. Everything's negotiable.

Robin Shepard
209.6281537.

Your
CLASSIFIED Ad
Here

Send your info, photos to:
r-m-s_57@comcast.net

1950 Land Cruiser in Oak Hills, \$11,500 (as seen in Craigslist)



Seller declares: "New radiator & water pump, New gas tank, sending unit, fuel pump & fuel lines, new brakes, new battery, good glass, windows roll up and down smoothly, new high quality interior with NOS materials, new carpet and headliner. White wall tires. Runs and drives great. All gauges work fine. Nice Chrome Bumpers and stainless trim. Under carriage nicely detailed and under hood as well. New windshield w/new seal, new back window seals, also new seals for wing window and many other new and used parts in the trunk Clean Calif Title on non-op or best offer. Any questions call 909-709-zerozero5zero."



Studebaker Drivers Club - San Joaquin Valley Chapter MEMBERSHIP APPLICATION

The Studebaker Drivers Club is an organization dedicated to the preservation, restoration and driving of all vehicles produced by the Studebaker Corporation. Owning a Studebaker is not a requirement for membership. Our chapter can offer technical and historical information, help in locating parts and an opportunity to take part in meets and other club activities and events. We have a monthly chapter newsletter, *Miles N' Smiles* and meet at 6:00 PM on the second Tuesday of each month (except July & December) at Black Bear Diner, 3602 W Shaw Ave (at N Marty Ave), Fresno, CA.

San Joaquin Valley Chapter dues are \$20.00 per year due in January (prorated \$1.66/mo for new members joining later in the year). Membership in the Studebaker Drivers Club National organization (see below) is a prerequisite for local Chapter membership for insurance purposes. If you have questions, please call Susan Thomason/SJVC Membership (559) 641-5125 or email to thomason2@earthlink.net.

NAME(S): _____ SDC MEMBER #/EXP DATE _____

ADDRESS: _____ CITY/STATE/ZIP: _____

HOME PHONE: _____ CELL: _____ EMAIL: _____

BIRTHDAY(S): _____ ANNIVERSARY _____

STUDEBAKER(S) OWNED

TO JOIN OUR CHAPTER

YEAR/MODEL/BODY TYPE	Mail this form and a check (payable to SJVC-SDC) to:
	Susan Thomason SJVC Membership 43306 Running Deer Drive Coarsegold, CA 93614

Studebaker Drivers Club NATIONAL MEMBERSHIP APPLICATION

Membership in the national organization is required to join a local chapter for insurance purposes. Annual Membership includes 12 issues of *Turning Wheels* magazine, the award-winning official publication of the SDC organization. You may join online at www.studebakerdriversclub.com, call **(763)420-7829** with a VISA or Master Card, fax to **(763)420-7849** or send this form to the address below. You may also include the national dues with your chapter dues above and our treasurer will send it for you. The SDC website also contains an abundance of information regarding Studebaker history and stories, parts availability, technical tips, classified ads and discussion forums as well as links to other Studebaker related sites.

Regular Membership with Periodicals Class Mail: New Members – FIRST YEAR ONLY: \$29.00 Regular Renewals/periodicals class mail: \$36.00 Student/Young Adult (up to age 22): \$29.00 Membership WITHOUT <i>Turning Wheels</i> : \$12.00 Regular Membership with First Class Mail: \$62.00	Mailing Address: The Studebaker Drivers Club, Inc. P.O. Box 1715 Maple Grove MN 55311-6715 For information: email mark@cornerstonereg.com
---	---

NAME _____ SPOUSE _____

ADDRESS: _____ CITY/STATE/ZIP: _____

PLEASE LIST YOUR STUDEBAKERS BELOW (Yr/Model/Body Type) NEW: _____ RENEWAL: _____